

9.01 车架总成/Chassis Frame Assembly

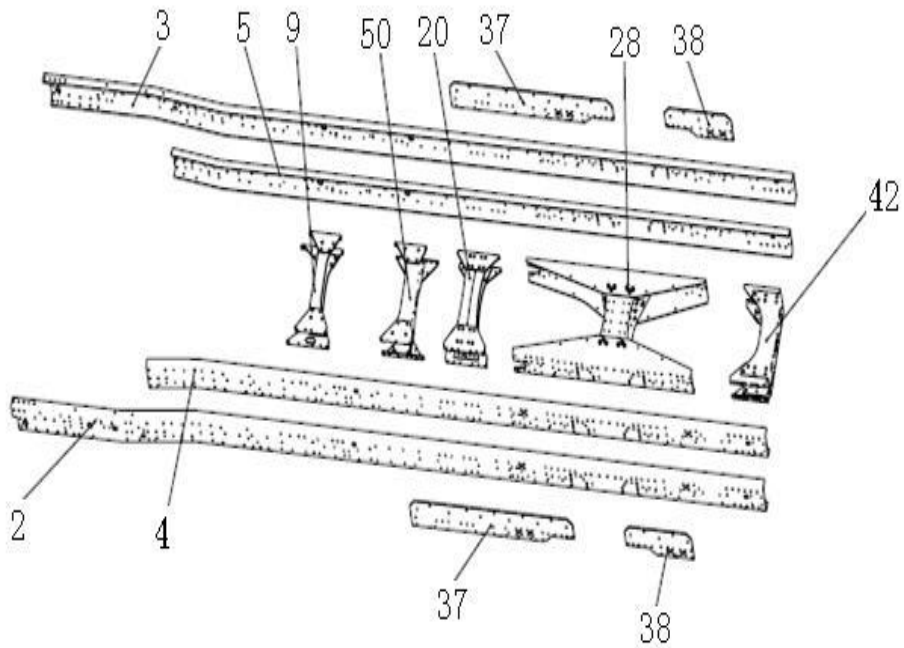

9.01 车架总成/Chassis Frame Assembly

序号	零部件图号	名称	Part Name	数量	备注
No.	Part No.			Qty	Remark
1	AZ9737513215	车架总成	Chassis frame ass.	1	
2	AZ9737513216	车架左纵梁	Left longeron	1	
3	AZ9737513217	车架右纵梁	Right longeron	1	
4	AZ9737513218	车架左加强梁	Left auxiliary beam	1	
5	AZ9737513219	车架右加强梁	Right auxiliary beam	1	
6	Q4501236	半圆头铆钉	Rivet	4	
9	WG9737510000	横梁总成	Cross member	1	
10	199000510021	横梁	Cross member	1	
15	Q4501232	半圆头铆钉	Rivet	16	
16	Q150B1645TF2	六角头螺栓	Screw	3	
17	Q33216T13F2	2型全金属六角螺母	Nut	3	
18	Q150B1240TF2	六角头螺栓	Screw	1	
19	Q33212T13F2	2型全金属六角锁紧螺母	Nut	1	
20	WG9737510050	横梁总成	Cross member	1	
21	AZ9625510816	横梁	Cross member	2	
22	AZ9625510817	横梁上连接板	Upper plate	2	
23	AZ9625510818	横梁下连接板	Lower plate	2	
24	Q4501230	半圆头铆钉	Rivet	36	
25	Q4501242	半圆头铆钉	Rivet	12	

9.01 车架总成/Chassis Frame Assembly

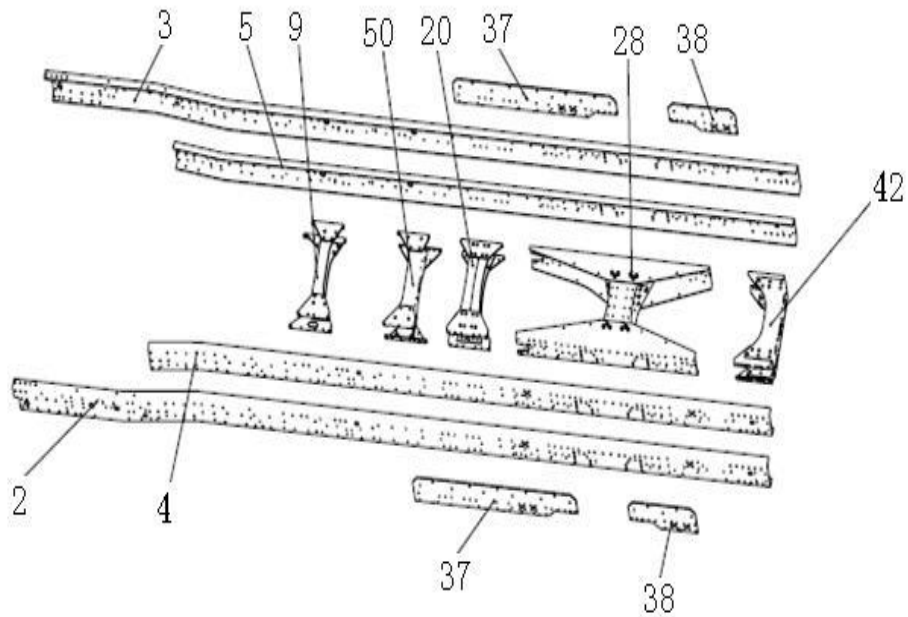

9.01 车架总成/Chassis Frame Assembly

序号 No.	零部件图号 Part No.	名称	Part Name	数量 Qty	备注 Remark
26	Q150B1635TF2	六角头螺栓	Screw	4	
27	Q33212T13F2	2型全金属六角锁紧螺母	Nut	4	
28	WG9725516006	横梁总成 (850/8+8)	Cross member	1	
29	AZ9625510816	左连接板	Left plate	1	
30	AZ9625510817	右连接板 (与左对称)	Right plate	1	
31	AZ9625510818	铸造横梁	Cross member	1	
33	Q150B1645TF2	六角头螺栓	Screw	12	
34	Q150B1240TF2	六角头螺栓	Screw	8	
35	Q33216T13F2	2型全金属六角螺母	Nut	12	
36	Q33212T13F2	2型全金属六角锁紧螺母	Nut	8	
37	WG9731510019	前支撑板	Front support plate	2	
38	WG9625510476	后支撑板	Rear support plate	2	
39	Q4501228	半圆头铆钉	Rivet	34	
40	Q4501252	半圆头铆钉	Rivet	26	
41	Q4501250	半圆头铆钉	Rivet	8	
42	WG9731513280	后横梁总成	Cross member ass. -rear	1	
47	Q4501232	半圆头铆钉	Rivet	24	
48	Q150B1645TF2	六角头螺栓	Screw	20	
49	Q33216T13F2	2型全金属六角螺母	Nut	20	

9.01 车架总成/Chassis Frame Assembly

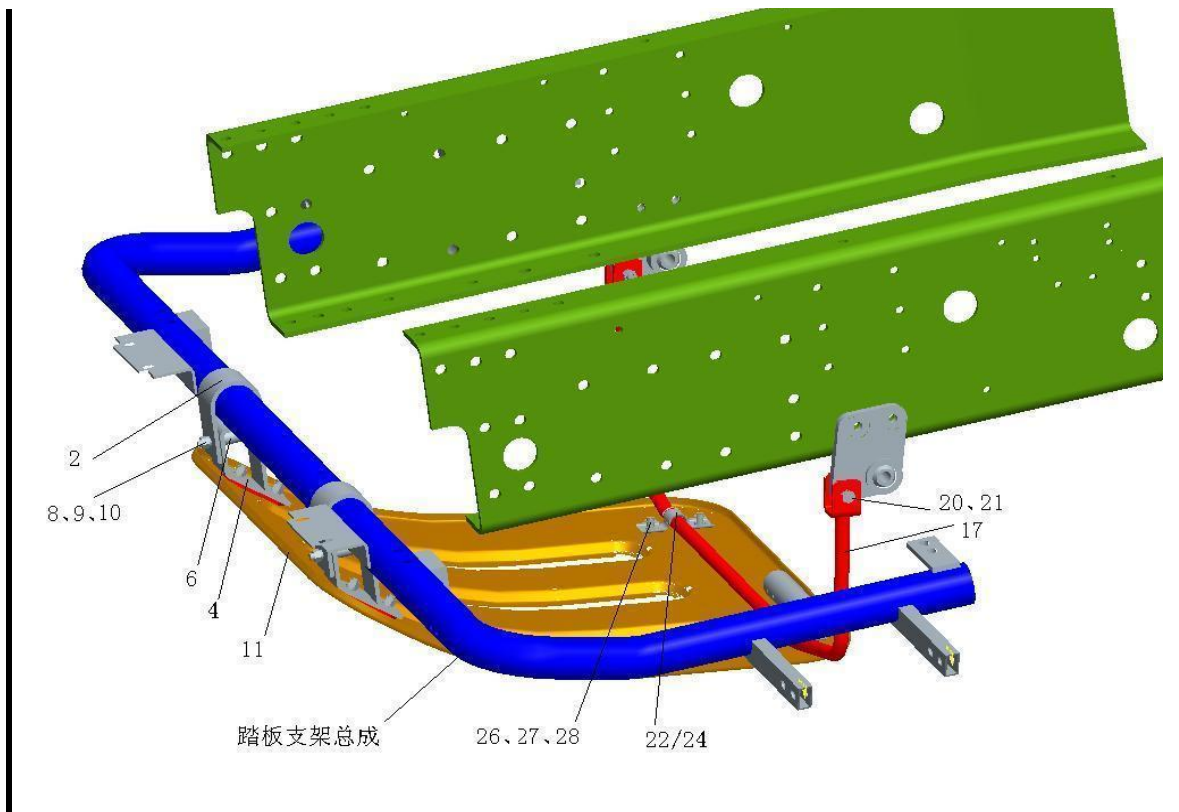

9.05 油底壳保护板/Protect Bracket for oil pan

序号	零部件图号	名称	Part Name	数量	备注
No.	Part No.			Qty	Remark
2	WG9725939063	U形板	Plate	2	
4	WG9725939064	下支架	Bracket	2	
6	WG9725939072	套管	Sleeve	2	
8	Q150B1090	六角头螺栓	Screw	2	
9	Q40310	弹簧垫圈	Spring washer	2	
10	Q33210	2型全金属六角锁紧螺母	Nut	2	
11	WG9725939061	保护板总成	Protect plate	1	
14	Q150B1030	六角头螺栓	Screw	4	
15	Q40310	弹簧垫圈	Spring washer	4	
16	Q33210	2型全金属六角锁紧螺母	Nut	4	
17	WG9725939065	吊架总成	Bracket	1	
20	Q150B1260TF2	六角头螺栓	Screw	2	
21	Q33212T13F2	2型全金属六角锁紧螺母	Nut	2	
22	WG9725939069	压板	Plate	2	
24	WG9725939068	垫板	Plate	2	
26	Q150B1025	六角头螺栓	Screw	4	
27	Q40310	弹簧垫圈	Spring washer	4	
28	Q33210	2型全金属六角锁紧螺母	Nut	4	

9.06 减震尾灯支架总成/Tailight Bracket

